

K-MAX

ROTARY CONTROL VALVE

Sizes 1" - 8" (25mm - 200mm) • ANSI Class 150 - 600





Armstrong International owns the exclusive rights to Aeroflow®, D-Boy™, DLO™, K-Max™, DOS, D-Series, and DOT™ Control Valves —all formerly sold by Leslie Controls. This includes the engineering and design of these product lines and all technical details.

Armstrong owns the exclusive rights to manufacture these legacy brands and OEM spare parts, adhering to the original specifications and drawings, and quality backed by the outstanding service, technical support and expertise Armstrong is known for. Armstrong International and its contractual representatives have exclusive rights to sell these product brands.

K-MAX ECCENTRIC PLUG ROTARY CONTROL VALVE

The K-MAX incorporates the cam action, low friction plug operation that provides tight shutoff over long service life in a wide variety of flow control applications.

The K-MAX Rotary Control Valve has improved on the performance and durability of traditional rotary control valves with the addition of these features:

BI-DIRECTIONAL FLOW CAPABILITY

The normal flow direction for clean liquids, gases, and steam is flow to open (flow into the face of the plug). The recommended flow direction for erosive and slurry service is flow to close (flow into the backside of the plug). Shutoff class is maintained in either flow direction.

ECCENTRIC ROTARY PLUG ACTION

The K-Max plug is offset to the shaft centerline. This allows the plug to break free of the seat ring immediately upon initial rotation of the shaft. Since there is no sliding contact between the plug and the seat ring throughout travel, seat ring life and shutoff integrity are greatly enhanced.

ECONOMICAL DESIGN

The inherent versatility of the K-Max offers the advantage of using one valve style for many applications, allowing for plant standardization and minimal stocking requirements. In addition, the efficient straight-through flow design allows for a much lower cost per C, than conventional globe style control valves.

RANGEABILITY

Rangeability of the K-Max valve is 100:1, allowing precise throttling over a wide range of flows.

SELF-ALIGNING ORBITAL SEAT

This innovative design allows orbital movement of the seat ring to provide self-alignment with the plug at assembly. Once seat ring to plug alignment is made, the seat is locked in place by the seat ring retainer. The seat ring and plug rigidly mate with every closure of the valve, maintaining excellent shutoff capability.



APPLICATIONS

The K-MAX Rotary Control Valve is engineered to handle nearly all industrial process control requirements including:

- | High and Low Pressure Steam
- | Clean, Dirty and Corrosive Liquids
- | Clean, Dirty and Corrosive Gas
- | Erosive and Abrasive Slurries

STANDARD FEATURES:

- 1 **Dual Spline Driven Shaft**
- 2 **Large Diameter 17-4PH Stem**
- 3 **Triple Bearing Shaft Support**
- 4 **Long Packing Life and Minimized Emissions Hazard**
provided by rotary valve operation.
- 5 **Fewer Possible Leak Paths**
due to one piece, integral bonnet design.
- 6 **Easy Trim Size Changes**
modify valve Cv by simply replacing seat ring.
- 7 **Customized Trim Options**
include Stainless Steel, Stellite®, and other alloys for a variety of applications such as:
 - | Slurry Service
 - | Corrosive Chemicals
 - | Erosive Conditions
 - | Superheated Steam
- 8 **Tight Shutoff over Extended Service Life**
provided by low friction, cam action offset plug mated with self-aligning orbital seat.
- 9 **Easy Maintenance and Clean-out**
assured by standard shaft access plug.

Variety of End Connections

- | Wafer Style (150, 300, 600 ANSI Class)
- | Separable Flanged (150, 300 ANSI Class)
- | Integral Flanged (150, 300, 600 ANSI Class)

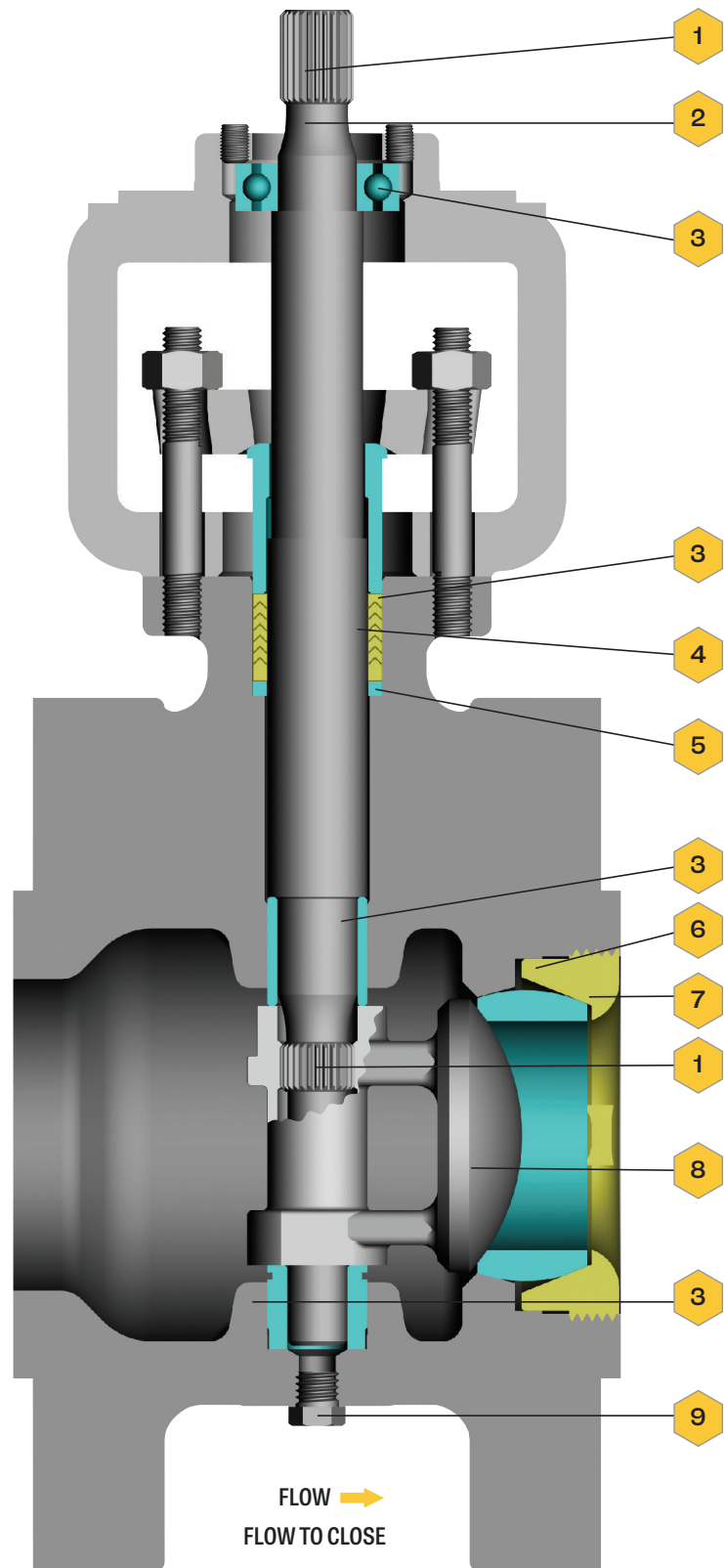



K-MAX Technical Specifications

VALVE STYLE

High performance eccentric rotary plug control valve.

Valve Size

Sizes 1" through 8" (25mm-200mm) with full or reduced port trim.

End Connection

Flangeless ANSI class 150, 300 or 600, sizes 1" - 8" (25-200 mm).

Separable flanged ANSI class 150 or 300, sizes 1" - 6" (25-152 mm).

Integral flanged ANSI class 150, 300 or 600, sizes (25-203 mm).

Note: Serrated raised face flanges are standard. Smooth raised face flanges, DIN and JIS flanges, available on application.

Seat Seal

Metal to metal seat (standard) – ANSI Class IV

Metal to metal seat (optional) – ANSI Class V

PTFE soft seat – ANSI Class VI (Full area Trim only)

The inherent flow characteristic of the K-Max valve is linear.

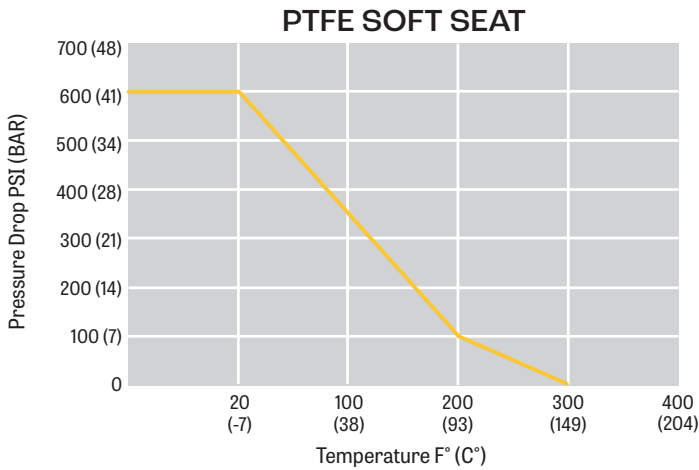

When required, the valve travel can be modified with a positioner cam adjustment to provide equal percent flow characteristic.

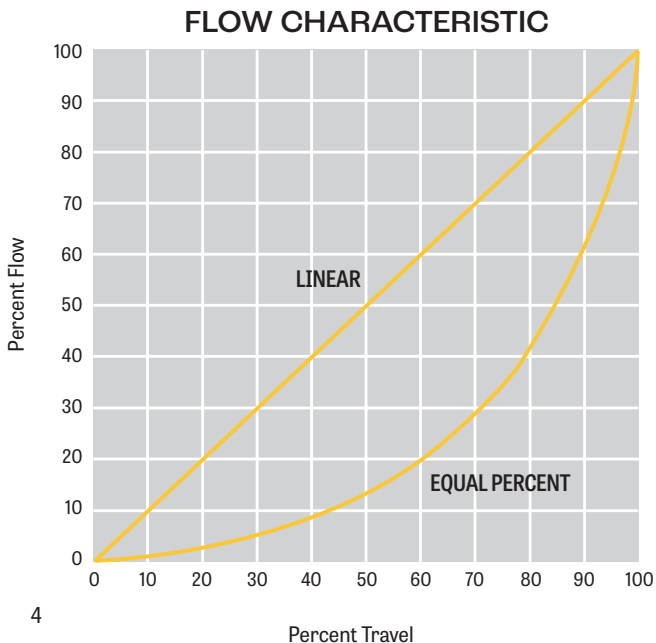

Body Material

Carbon steel, ASTM A216 grade WCB

316 stainless steel, ASTM A351 grade CF8M

Alloy20, HAST-C, Titanium

Packing	
Packing Type	Temperature Range F° (C°)
Teflon® Chevron	-40 (-40) through +450 (232)
Laminated Graphite	-300 (-184) through +800 (427)
Teflon® Chevron with Viton Bearing Seals	-40 (-40) through +450 (232)

Trim Material

See K-Max valve material specifications.

Note: Other trim combinations available on application.

ALLOY 6 TRIM OPTIONS:

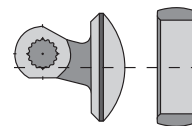
- 

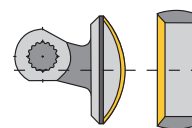
No Alloy 6
No Alloy 6 on seat ring or plug.
- 

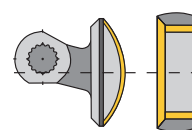
Partial Alloy 6
Alloy 6 on seat ring and plug seating surfaces.
- 

Full Alloy 6
Alloy 6 on seat ring bore in addition to seat ring and plug seating surfaces.

ALLOY 6 RECOMMENDED USAGE

(ANSI CLASS 600 RATING)

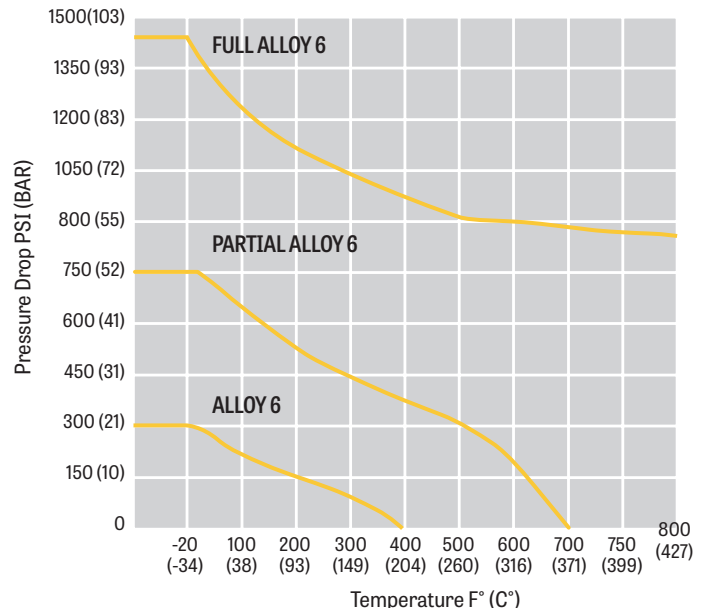

K-MAX Technical Specifications



Trim Size

Full size trim – 100% capacity

.6 reduced trim – 60% of full capacity

.4 reduced trim – 40% of full capacity

.2 reduced trim – 20% of full capacity

Note: Other trim sizes available on application.

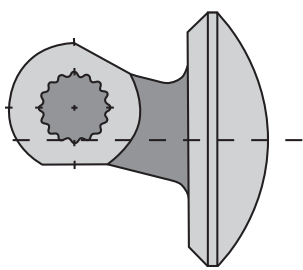

Common Plug For
All Trim Sizes

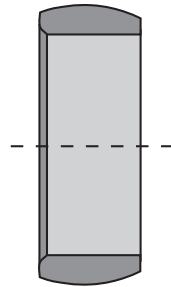

Full Port Seat
(100% Capacity)

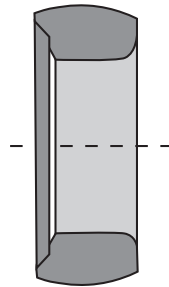

.6 Reduced Port Seat
(60% Capacity)

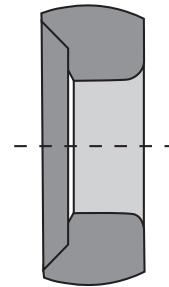

.4 Reduced Port Seat
(40% Capacity)

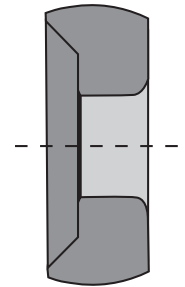

.2 Reduced Port Seat
(20% Capacity)

Options

- | Fluoroelastomer bearing seal for slurry service
- | Kalrez® bearing seal for slurry service
- | Carbon Steel or 316 stainless steel separable flanges and retaining rings
- | 316 stainless steel valve to actuator bolting
- | NACE trim - conforms to NACE MR0103 & MR0175z

STANDARD CLASS

Temp. °F (C°)	Working Pressure by Classes, PSIG (BAR)		
	150	300	600
-20 (-29) to 100 (38)	285 (20)	740 (51)	1480 (102)
200 (93)	260 (18)	675 (46)	1350 (93)
300 (149)	230 (16)	655 (45)	1315 (91)
400 (204)	200 (14)	635 (44)	1270 (88)
500 (260)	170 (12)	600 (41)	1200 (83)
600 (316)	140 (10)	550 (38)	1095 (75)
650 (343)	125 (9)	535 (37)	1075 (74)
700 (371)	110 (8)	535 (37)	1065 (73)
750 (399)	95 (7)	505 (35)	1010 (70)
800 (427)	80 (6)	410 (26)	825 (57)
850 (454)	65 (4)	270 (219)	535 (37)
900 (482)	50 (3)	170 (12)	345 (24)
950 (510)	35 (2)	105 (7)	205 (14)
1000 (538)	20 (1)	50 (3)	105 (7)

RECOVERY COEFFICIENTS FL (ALL FLUIDS) & CAVITATION INDEX KC (LIQUIDS)

Valve Opening %	Flow to Open		Flow to Close	
	F _L	K _c	F _L	K _c
100	.88	.60	.75	.56
90	.89	.61	.74	.49
80	.89	.62	.73	.49
70	.90	.63	.73	.49
60	.89	.62	.75	.50
50	.89	.61	.78	.51
40	.88	.61	.80	.52
30	.88	.60	.82	.53
20	.87	.59	.84	.55
10	.87	.59	.85	.55

Note: For calculating the pressure drop at which cavitation will begin, ΔP_c multiply K_c by the quantity $P_1 - P_v$, where P_1 = upstream pressure (PSIA), and P_v = vapor pressure (PSIA). $\Delta P_c = K_c (P_1 - P_v)$.

Not recommended for prolonged usage above about 800°F



K-MAX Specifications

Trim Material Code	Body Material	Plug Material	Seat Ring Material		Shaft Material	Bearing Material
			Size 2"-8" (51-203 mm) Full Trim Valves	Size 1"-1.5" (25-38 mm) Full Trim Valves and Size 1"-8" (25-203 mm) Reduced Trim Valves		
S	Carbon Steel ASTM A216 WCB	316 Stainless Steel ASTM A351 CF8M w/hardened electroless nickel coating	316 Stainless Steel ASTM A351 CF8M Hardness Brinell 150	316 Stainless Steel ASTM A479 316 Hardness Brinell 150	17-4 PH Stainless Steel ASTM A564 S17400 condition H900 Hardness Rockwell C40	440C Stainless Steel ASTM A276 S44004 Hardness Rockwell C 58
	316 Stainless Steel ASTM A351 CF8M	316 Stainless Steel ASTM A351 CF8M w/hardened electroless nickel coating	316 Stainless Steel ASTM A351 CF8M Hardness Brinell 150 nickel coating	316 Stainless Steel ASTM A479 316 Hardness Brinell 150	17-4 PH Stainless Steel ASTM A564 S17400 condition H900 Hardness Rockwell C40	Alloy 6 AMS 5387B Hardness Rockwell C 37-41
P or F	Carbon Steel ASTM A216 WCB	316 Stainless Steel ASTM A351 CF8M w/Alloy 6 hard overlay AWS A5.13 RCoCr - A Hardness Rockwell C 38 - 47	Alloy 6	316 Stainless Steel ASTM A479 316 Alloy 6 Hardness Rockwell C 38 - 47	17-4 PH Stainless Steel ASTM A564 S17400 condition H900 Hardness Rockwell C 40	440C Stainless Steel ASTM A276 S44004 Hardness Rockwell C 58
	316 Stainless Steel ASTM A315 CF8M	316 Stainless Steel ASTM A351 CF8M w/Alloy 6 hard overlay AWS A5.13 RCoCr - A Hardness Rockwell C 38 - 47	Alloy 6	316 Stainless Steel ASTM A479 316 Alloy 6 Hardness Rockwell C 38 - 47	17-4 PH Stainless Steel ASTM A564 S17400 condition H900 Hardness Rockwell C 40	Alloy 6 AMS 5387B Hardness Rockwell C 37-41
A	Alloy 20 ASTM A315 CN7M	Alloy 20 ASTM A351 CN7M Hardness Brinell 130	Alloy 20 ASTM A351 CN7M Hardness Brinell 130	Alloy 20 Cb3 ASTM B473 N08020 Hardness Brinell 183	Titanium 5 ASTM B348 Grade 5 Hardness Rockwell C 36	Hastelloy C ASTM B574 N10276 Hardness Brinell 184
H	Hastelloy C22 ASTM A494 CX2MW	Hastelloy C ASTM A494 CX2MW Hardness Brinell 200	Hastelloy C ASTM A494 CX2MW Hardness Brinell 200	Hastelloy C ASTM B574 N10276 Hardness Brinell 184	Titanium 5 ASTM B348 Grade 5 Hardness Rockwell C 36	Hastelloy C ASTM B574 N10276 Hardness Brinell 184
T	Titanium C3 ASTM B367 C-3	Titanium C3 ASTM B367 C-3 Hardness Brinell 235 maximum	Titanium C3 ASTM B367 C-3 Hardness Brinell 235 maximum	Titanium 5 ASTM B348 Grade 5 Hardness Rockwell C 36	Titanium 5 ASTM B348 Grade 5 Hardness Rockwell C 36	Ceramic Partially Stabilized zirconium Grade M S

Note: Seat ring retainer material is the same as the base plug material.

ACTUATOR DIMENSIONS

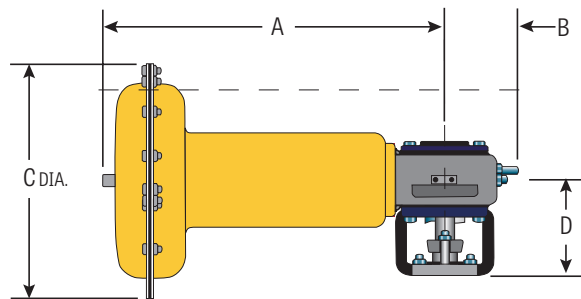

ACTUATOR DIMENSIONS INCHES (MM) AND WEIGHTS POUNDS (KG)

Actuator Size	Dimensions in (mm)				Weights lbs (k)
	A	B	C	D	
40	11.25 (286)	3.5 (88.9)	10.12 (257)	6.5 (165)	29 (13)
55	18.5 (470)	5.25 (133)	12.00 (305)	6.56 (167)	80 (36)
85	19.88 (505)	5.25 (133)	14.75 (375)	7.44 (189)	110 (50)

Actuator Mounting Positions

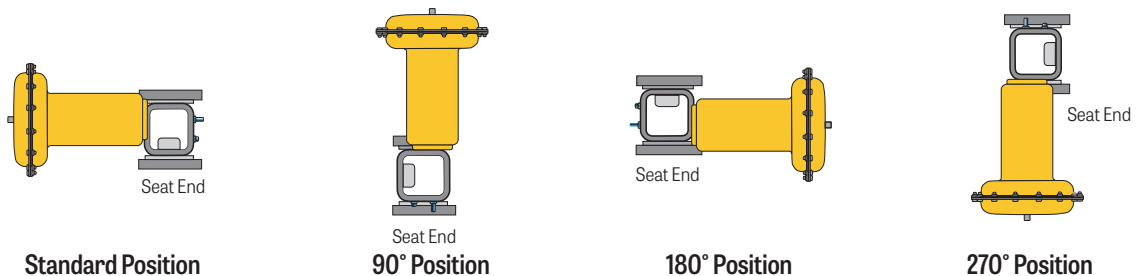

K-MAX Body Dimensions

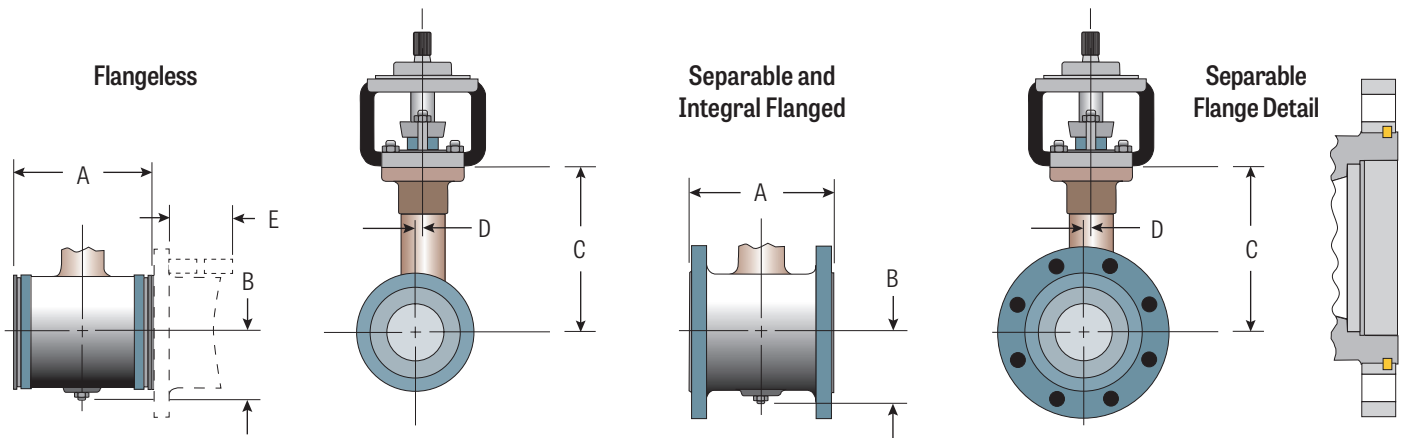

Size in (mm)	Dimensions													Weights			
	A	B	C	D	E	F	G	H	J	K	L	M	N	Flgless	FL150	FL300	FL600
1 (25)	4 (102)	27/16 (62)	47/16 (113)	5/32 (4.06)	75/8 (194)	1 (25)	1 1/2 (38.1)	11/16 (17.5)	—	15/16 (23.9)	—	7/16 (11.2)	3/4 (82.6)	9 (4.1)	12 (5.4)	14 (6.4)	17 (7.7)
1 1/2 (40)	4 1/2 (114)	2 3/4 (69.8)	5 1/8 (130)	1/4 (6.35)	8 3/4 (222)	1 (25)	1 1/2 (38.1)	11/16 (17.5)	—	15/16 (23.9)	—	7/16 (11.2)	3/4 (82.6)	13 (5.9)	18 (8.2)	23 (10)	27 (12)
2 (50)	4 7/8 (124)	2 19/16 (71.4)	4 7/8 (124)	7/32 (5.59)	9 1/8 (232)	1 (25)	1 1/2 (38.1)	11/16 (17.5)	—	15/16 (23.9)	—	7/16 (11.2)	3/4 (82.6)	14 (6.4)	21 (9.5)	25 (11)	30 (14)
3 (80)	6 1/2 (165)	39/16 (90.4)	5 3/4 (146)	5/16 (7.87)	11 1/2 (292)	1 1/4 (32)	27/16 (62)	13/16 (20.6)	7/8 (22.4)	3/4 (19)	5 (125)	9/16 (14.2)	6 1/2 (165)	31 (14)	43 (20)	52 (24)	58 (26)
4 (100)	7 5/8 (194)	4 (100)	7 (178)	7/16 (11.2)	133/8 (340)	1 1/4 (32)	27/16 (62)	13/16 (20.6)	7/8 (22.4)	3/4 (19)	5 (125)	9/16 (14.2)	6 1/2 (165)	42 (19)	60 (27)	76 (34)	100 (45)
6 (150)	9 (229)	51/16 (129)	99/16 (244)	11/16 (16.8)	15 3/4 (400)	1 3/4 (44.4)	25/16 (58.7)	15/16 (23.9)	7/16 (11.2)	11/16 (16.8)	5 (125)	9/16 (14.2)	6 1/2 (165)	97 (44)	119 (54)	152 (69)	207 (94)
8 (200)	99/16 (243)	6 (150)	11 (279)	7/8 (22.4)	17 3/4 (438)	1 3/4 (44.4)	25/16 (58.7)	15/16 (23.9)	7/16 (11.2)	11/16 (16.8)	5 (125)	9/16 (14.2)	6 1/2 (165)	144 (65)	180 (82)	222 (101)	304 (138)

- Note: 1. All dimensions are subject to change without notice. Request certified drawings for use in preparing piping layouts.
- 2. Flange dimensions conform to ANSI B16.5.
- 3. Face-to-face dimensions conform to ISA S75.04.
- 4. Weights shown do not include crating.

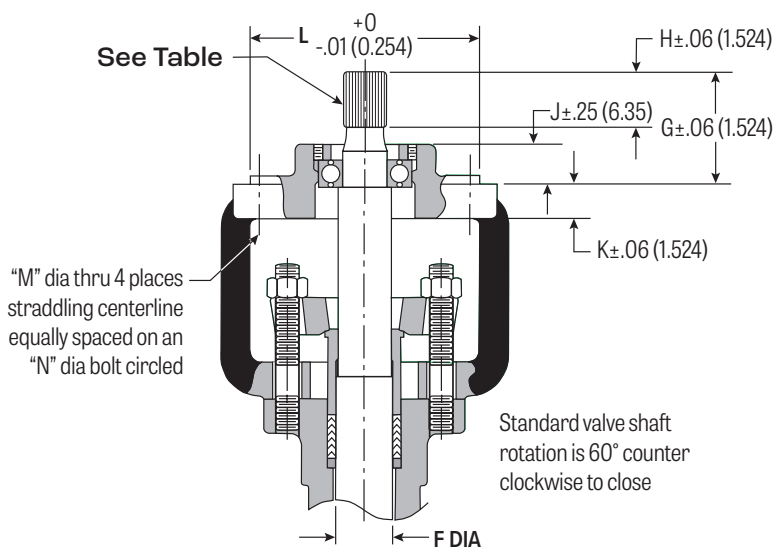

Feature	Valve Size		
	1, 1.5, 2	3, 4	6, 8
Fillet Root Side Fit			
Number of teeth	28	28	52
Pitch	40/80	32/64	40/80
Pressure angle	30°	30°	30°
Base diameter	.6062 (15.397)	.7578 (19.248)	1.1258 (28.595)
Pitch diameter	.7 (17.780)	.875 (22.225)	1.3 (33.020)
Major diameter	.725/.722 (18.415/18.334)	.906/.903 (23.012/22.936)	1.325/1.322 (33.655/33.579)
Form diameter	.671 (17.043)	.839 (21.311)	1.271 (32.283)
Minor diameter	.638 (16.205)	.8 (20.32)	1.236 (31.394)
Circular Tooth Thickness			
Max. effective	.0390 (.9906)	.0491 (1.247)	.0393 (.998)
Min. actual	.0366 (.9296)	.0464 (1.179)	.0361 (.917)



FLOW COEFFICIENTS (C_v), LINEAR CHARACTERISTIC

Flow to Open		Percent Travel (60°) Rotation									
Valve Size	Trim Size	10%	20%	30%	40%	50%	60%	70%	80%	90%	100%
1	Full	1.3	2.8	4.2	5.9	7.8	9.1	11	12	13	14
	.6 reduced	.76	1.6	2.5	3.5	4.8	5.5	6.4	7.4	7.9	8.4
	.4 reduced	.50	1.1	1.7	2.4	3.2	3.7	4.3	4.9	5.3	5.6
	.2 reduced	.25	.53	.84	1.2	1.6	1.8	2.1	2.5	2.6	2.8
1.5	Full	2.9	6.1	9.6	13	18	21	24	28	30	32
	.6 reduced	2.7	5.7	9.0	11	12	13	15	17	18	20
	.4 reduced	1.2	2.5	3.9	5.5	7.4	8.6	9.8	11	12	13
	.2 reduced	.59	1.2	2.0	2.8	3.7	4.3	4.9	5.7	6.1	6.5
2	Full	4.6	9.7	15	21	29	34	39	45	48	51
	.6 reduced	2.7	5.7	9.0	13	17	20	23	26	28	30
	.4 reduced	1.8	3.8	6.0	8.4	11	13	15	18	19	20
	.2 reduced	2.7	5.7	9.0	13	17	20	23	26	28	30
3	Full	14	29	45	63	86	99	114	132	141	150
	.6 reduced	8.1	17	27	38	51	59	68	79	85	90
	.4 reduced	5.4	11	18	25	34	40	46	53	56	60
	.2 reduced	2.7	5.4	9.0	13	17	20	23	26	28	30
4	Full	22	47	74	104	141	163	187	217	232	247
	.6 reduced	13	28	44	62	84	97	112	129	138	147
	.4 reduced	8.8	19	29	41	56	65	75	86	92	98
	.2 reduced	4.4	9.3	15	21	28	32	37	43	46	49
6	Full	47	99	156	218	296	343	395	458	489	520
	.6 reduced	28	59	89	125	170	206	225	275	294	312
	.4 reduced	19	40	59	83	113	137	150	183	196	208
	.2 reduced	9.4	20	30	42	57	69	75	92	98	104
8	Full	78	165	261	365	496	574	661	766	818	870
	.6 reduced	47	99	156	219	297	345	396	459	491	522
	.4 reduced	31	66	104	146	198	230	264	306	327	348
	.2 reduced	16	33	52	73	99	115	132	153	164	174

Flow to Close		Percent Travel (60°) Rotation									
Valve Size	Trim Size	10%	20%	30%	40%	50%	60%	70%	80%	90%	100%
1	Full	1.4	2.9	4.5	6.3	8.6	9.9	11	13	14	15
	.6 reduced	.81	1.7	2.7	3.8	5.1	5.9	6.8	7.9	8.5	9.0
	.4 reduced	.54	1.1	1.8	2.5	3.4	4.0	4.6	5.3	5.6	6.0
	.2 reduced	.27	.57	.90	1.3	1.7	2.0	2.3	2.6	2.8	3.0
1.5	Full	3.1	6.5	10	14	19	22	26	30	32	34
	.6 reduced	1.9	4.0	6.3	8.8	12	14	16	19	20	21
	.4 reduced	1.3	2.7	4.2	5.9	8.0	9.2	11	12	13	14
	.2 reduced	.63	1.3	2.1	2.9	4.0	4.6	5.3	6.2	6.6	7.0
2	Full	5.0	11	17	23	31	36	42	48	52	55
	.6 reduced	2.7	5.7	9.0	13	17	20	24	29	30	33
	.4 reduced	1.8	3.8	6.0	8.4	11	13	16	19	20	22
	.2 reduced	.90	1.9	3.0	4.2	5.7	6.5	8.0	9.0	10	11
3	Full	14	30	47	65	88	102	118	136	146	155
	.6 reduced	8.4	18	28	39	53	61	71	81	87	93
	.4 reduced	5.6	12	19	26	35	41	47	54	58	62
	.2 reduced	2.8	5.9	9.3	13	15	21	24	27	29	31
4	Full	24	51	80	112	152	176	202	234	250	266
	.6 reduced	14	30	48	67	90	95	120	140	149	159
	.4 reduced	9.5	20	32	45	60	63	80	93	99	106
	.2 reduced	4.8	10	16	22	30	32	40	47	50	53
6	Full	43	91	144	202	273	316	364	422	451	480
	.6 reduced	26	55	86	120	164	189	219	254	270	288
	.4 reduced	17	37	58	80	109	126	146	169	180	192
	.2 reduced	9.6	18	29	40	55	63	73	85	90	96
8	Full	72	152	240	336	456	528	608	704	752	800
	.6 reduced	43	90	144	201	273	317	365	422	450	480
	.4 reduced	29	60	96	134	182	211	243	281	300	320
	.2 reduced	14	30	48	67	91	106	122	141	150	160

TORQUE REQUIREMENTS TO ACHIEVE ANSI CLASS IV, V OR VI SHUTOFF

Valve Size in (mm)	Shut off Pressure Drop psi (bar)													
	30 (2.1)	50 (3.4)	100 (6.9)	200 (13.8)	300 (20.7)	400 (27.6)	500 (34.5)	600 (41.4)	700 (48.3)	800 (55.2)	900 (62.1)	1000 (68.9)	1200 (82.8)	1440 (99.3)
1 (25)	10.8 (0.7)	11.0 (0.8)	11.5 (0.8)	12.2 (0.8)	12.9 (0.9)	13.8 (1.0)	14.6 (1.0)	15.4 (1.1)	16.2 (1.1)	16.9 (1.2)	17.8 (1.2)	18.6 (1.3)	20.0 (1.4)	21.8 (1.5)
1.5 (38)	19.5 (1.3)	19.9 (1.4)	21.2 (1.5)	23.4 (1.6)	25.8 (1.8)	28.0 (1.9)	30.3 (2.1)	32.7 (2.3)	34.9 (2.4)	37.3 (2.6)	39.6 (2.7)	42.4 (2.9)	46.5 (3.2)	51.1 (3.5)
2 (51)	28.7 (2.0)	29.5 (2.0)	31.4 (2.2)	35.3 (2.4)	39.3 (2.7)	43.3 (3.0)	47.3 (3.3)	51.3 (3.5)	55.2 (3.8)	59.2 (4.1)	63.1 (4.4)	67.4 (4.6)	74.9 (5.2)	78.8 (5.4)
3 (76)	61.3 (4.2)	63.7 (4.4)	69.7 (4.8)	81.7 (5.6)	93.6 (6.5)	106 (7.3)	117 (8.1)	129 (8.9)	142 (9.8)	153 (10.6)	165 (11.4)	177 (12.2)	193 (13.3)	210 (14.5)
4 (102)	110 (7.6)	116 (8.0)	130 (9.0)	160 (11.0)	189 (13.0)	218 (15)	248 (17.1)	277 (19.1)	306 (21.1)	336 (33.2)	365 (25.2)	394 (27.2)	—	—
6 (152)	229 (15.8)	252 (17.4)	299 (20.7)	393 (27.1)	487 (33.6)	582 (40.1)	676 (46.6)	770 (53.1)	—	—	—	—	—	—
8 (203)	397 (27.3)	442 (30.5)	552 (38.1)	773 (53.3)	994 (68.5)	—	—	—	—	—	—	—	—	—

MAXIMUM ALLOWABLE DIFFERENTIAL PRESSURE PSI (BAR)

Based on Torsional Shear Strength of Shaft

Valve Size in (mm)	Shaft Material
	17-4 SST
1 (25)	1440 (99.2)
1.5 (38)	1440 (99.2)
2 (51)	1440 (99.2)
3 (76)	1440 (99.2)
4 (102)	1000 (68.9)
6 (152)	1000 (68.9)
8 (203)	550 (37.9)

MAXIMUM ALLOWABLE SHAFT TORQUES

Foot Pounds (Newton meters)

Valve Size in (mm)	Shaft Material
	17-4 SST
1 (25)	210 (285)
1.5 (38)	210 (285)
2 (51)	210 (285)
3 (76)	390 (529)
4 (102)	390 (529)
6 (152)	1550 (2102)
8 (203)	1550 (2102)

DIAPHRAGM ACTUATOR OUTPUT TORQUES

Actuator Size	Actuator Action	Actuator Spring psi (bar)	Output Torque Ft-lbs (Nm)
40	Air to Open	20 (1.4)	31 (42)
	Air to Close	20 (1.4)	19 (26)
	Air to Open	35 (2.4)	58 (79)
	Air to Close	35 (2.4)	58 (79)
55	Air to Open	60 psi	95 (129)
	Air to Close	60 psi	102 (138)
	Air to Open	20 (1.4)	88 (119)
	Air to Close	20 (1.4)	76 (103)
85	Air to Open	35 (2.4)	152 (206)
	Air to Close	35 (2.4)	124 (168)
	Air to Open	60 (4.1)	263 (357)
	Air to Close	60 (4.1)	224 (304)
85	Air to Open	20 (1.4)	130 (176)
	Air to Close	20 (1.4)	130 (176)
	Air to Open	35 (2.4)	220 (298)
	Air to Close	35 (2.4)	221 (300)
85	Air to Open	60 (4.1)	389 (527)
	Air to Close	60 (4.1)	389 (527)



K-MAX Actuator Sizing

FULL PORT, AIR TO OPEN, FLOW-TO-OPEN & FLOW-TO-CLOSE

Valve Size in (mm)	Actuator Code	Maximum Shutoff Pressure Differential		
		Air Supply psi (bar)		
		20 (1.4)	35 (2.4)	60 (4.1)
1 (25)	DR-40-R-60	—	—	1440 (99.3)
	DR-40-R-35	—	1440 (99.3)	—
	DR-40-R-20	1440 (99.3)	—	—
1.5 (38)	DR-40-R-60	—	—	1440 (99.3)
	DR-40-R-35	—	1440 (99.3)	—
	DR-40-R-20	500 (34.5)	—	—
2 (51)	DR-40-R-60	—	—	1440 (99.3)
	DR-40-R-35	—	800 (55.2)	—
	DR-40-R-20	100 (6.9)	—	—
3 (76)	DR-55-R-60*	—	—	1400 (96.5)
	DR-55-R-35	—	775 (53.4)	—
	DR-55-R-20	250 (17.2)	—	—
	DR-85-R-35*	—	1440 (99.3)	—
	DR-85-R-20	600 (41.4)	—	—
4 (102)	DR-55-R-60*	—	—	540 (37.2)
	DR-55-R-35	—	100 (6.9)	—
	DR-55-R-20	25 (1.7)	—	—
	DR-85-R-35*	—	400 (27.6)	—
	DR-85-R-20	100 (6.9)	—	—
6 (152)**	DR-85-R-60	—	—	200 (13.8)
	DR-85-R-35	—	25 (1.7)	—
8 (203)**	DR-85-R-60	—	—	25 (1.7)

FULL PORT, AIR TO CLOSE, FLOW-TO-OPEN & FLOW-TO-CLOSE

Valve Size in (mm)	Actuator Code	Maximum Shutoff Pressure Differential		
		Air Supply PSI (bar)		
		20 (1.4)	35 (2.4)	60 (4.1)
1 (25)	DR-40-D-60	—	—	1440 (99.3)
	DR-40-D-35	—	1440 (99.3)	—
	DR-40-D-20	1200 (82.7)	—	—
1.5 (38)	DR-40-D-60	—	—	1440 (99.3)
	DR-40-D-35	—	1440 (99.3)	—
	DR-40-D-20	75 (5.2)	—	—
2 (51)	DR-40-D-60	—	—	1440 (99.3)
	DR-40-D-35	—	800 (55.2)	—
	DR-40-D-20	20 (1.4)	—	—
3 (76)	DR-55-D-60*	—	—	1400 (96.5)
	DR-55-D-35	—	560 (38.6)	—
	DR-55-D-20	150 (10.3)	—	—
	DR-85-D-35*	—	1440 (99.3)	—
	DR-85-D-20	600 (41.4)	—	—
4 (102)	DR-55-D-60*	—	—	425 (29.3)
	DR-55-D-35	—	100 (6.9)	—
	DR-55-D-20	20 (1.4)	—	—
	DR-85-D-35*	—	400 (27.6)	—
	DR-85-D-20	100 (6.9)	—	—
6 (152)**	DR-85-D-60	—	—	200 (13.8)
	DR-85-D-35	—	25 (1.7)	—
8 (203)**	DR-85-D-60	—	—	25 (1.7)

Valve Size in (mm)	Actuator Code	Maximum Shutoff Pressure Differential		
		Air Supply psi (bar)		
		20 (1.4)	35 (2.4)	60 (4.1)
1 (25) & 1.5 (38)	DR-40-R-60	—	—	1440 (99.3)
	DR-40-R-35	—	1440 (99.3)	—
	DR-40-R-20	1440 (99.3)	—	—
2 (51)	DR-40-R-60	—	—	1440 (99.3)
	DR-40-R-35	—	1440 (99.3)	—
	DR-40-R-20	800 (55.2)	—	—
3 (76)	DR-55-R-60*	—	—	1400 (96.5)
	DR-55-R-35	—	1440 (99.3)	—
	DR-55-R-20	400 (27.6)	—	—
	DR-85-R-20	960 (66.2)	—	—
4 (102)	DR-55-R-60*	—	—	1400 (96.5)
	DR-55-R-35	—	200 (13.8)	—
	DR-55-R-20	40 (2.8)	—	—
	DR-85-R-35*	—	640 (44.1)	—
	DR-85-R-20	160 (11.0)	—	—
6 (152)**	DR-85-R-60	—	—	690 (47.6)
	DR-85-R-35	—	120 (8.3)	—
8 (203)**	DR-85-R-60	—	—	295 (20.3)

Valve Size in (mm)	Actuator Code	Maximum Shutoff Pressure Differential		
		Air Supply psi (bar)		
		20 (1.4)	35 (2.4)	60 (4.1)
1 (25) & 1.5 (38)	DR-40-D-60	—	—	1440 (99.3)
	DR-40-D-35	—	1440 (99.3)	—
	DR-40-D-20	1440 (99.3)	—	—
2 (51)	DR-40-D-60	—	—	1440 (99.3)
	DR-40-D-35	—	1440 (99.3)	—
	DR-40-D-20	800 (55.2)	—	—
3 (76)	DR-55-D-60*	—	—	1400 (96.5)
	DR-55-D-35	—	1440 (99.3)	—
	DR-55-D-20	240 (16.5)	—	—
	DR-85-D-20	960 (66.2)	—	—
4 (102)	DR-55-D-60*	—	—	1400 (96.5)
	DR-55-D-35	—	200 (13.8)	—
	DR-55-D-20	30 (2.1)	—	—
	DR-85-D-35*	—	640 (44.1)	—
	DR-85-D-20	160 (11.0)	—	—
6 (152)**	DR-85-D-60	—	—	690 (47.6)
	DR-85-D-35	—	120 (8.3)	—
8 (203)**	DR-85-D-60	—	—	295 (20.3)

*Not for use with trim material S3. **For higher differential pressures, consult factory.

Rotary 2-Way Control Valves



K-MAX CODE SELECTION CHART

Class - Position 1 & 2	Trim Factor - Position 8
KR	1 = Full Capacity
Material - Position 3	6 = 0.6 (16)
C = Carbon Steel	4 = 0.4 (10)
S = CF8M (SST)	2 = 0.2 (5)
A = CN7M (Alloy 20)	X = Other
H = CX2MW (C22)	Shut 0 - Position 9
T = Grade C-3	4 = Class IV, Std
X = Other	5 = Class V, Optional
Valve Size - Position 4	6 = Class VI, Soft Seat Only
0 = 1" (25)	Packing - Position 10
1 = 1.5" (38)	G = Laminated Graphite
2 = 2" (51)	T = Teflon-Chevron
3 = 3" (76)	V = TFE V-ring with Viton-sealed bushings
4 = 4" (102)	X = Other
6 = 6" (152)	Flow Direction - Position 11
8 = 8" (203)	O = Flow to Open
X = Other	C = Flow to Close
End Connection - Position 5	Actuator - Position 12
W = Wafer	A = DR-40-D
L = CS Separable Flanges	B = DR-40-R
S = SS Separable Flanges	C = DR-55-D
F = Integral Flanges	D = DR-55-R
X = Other	E = DR-85-D
Valve Rating - Position 6	F = DR-85-R
1 = ANSI 150	N = None
2 = ANSI 300	Spring - Position 13
3 = ANSI 600	2 = 20
4 = ANSI 150 SEP	3 = 35
5 = ANSI 300 SEP	6 = 60 (Std)
6 = ANSI 600 SEP	Z = No Actuator
X = Other	HOD - Position 14
Trim Material - Position 7	N = None
S = Std 316 SS	H = Handwheel
P = Partial Stellite	J = HandJack
F = Full Stellite	Z = No Actuator
A = Alloy 20	Actuator Orientation - Position 15
H = Hast C	A = Standard
T = Titanium	B = 90 Deg
R = 316/TFE	C = 180 Deg
X = Other	D = 270 Deg
	Z = No Actuator

K	R	C	O	W	3	P	6	5	T	C	B	2	N	A	-	1	C	2	B	3	A	C	E
1	2	3	4	5	6	7	8	9	10	11	12	13	14	15	17	18	19	20	21	22	23	24	

Tubing - Position 17
0 = None
1 = Brass
2 = Stainless Steel

Positioner - Position 18
0 = None
A = Moore 760P 3-15 psi (KM1205682)
B = Moore 760E 4-20 ma (KM1205683)
C = 760P w/4-20 feedback KM1205682+A78727
D = 760E w/4-20 feedback KM1205683+A78727
E = Siemens PS2 (Single-Acting)* (A80581)
G = PS2 (Single) w/ Feedback* (A80581 w/ A83498)
M = Moore 760P 3-27 psi (A79104 w/ A79661)
X = Other

Regulator - Position 19
0 = None
2 = AFG-2 (3-60 psi) (0.2-4.1 bar)
5 = AS-1 (.5-60 psi) (.03-4.1 bar)
8 = ASG-1 (.5-60 psi) (.03-4.1 bar)
X = Other

Solenoid - Position 20
0 = None
A = ASCO 3-Way Universal 120VAC (A69750)
B = ASCO 3-Way Universal 24VDC (A80662)
X = Other

Switch - Position 21
0 = None
1 = Honeywell LSA7L-1B DPDT (1 Ea)
2 = Honeywell LSA7L-1B DPDT (2 Ea)
3 = Honeywell BZE6-2RN SPDT (1 Ea)
4 = Honeywell BZE6-2RN SPDT (2 Ea)
5 = Namco EA-170-11100 DPDT (1 Ea)
6 = Namco EA-170-11100 DPDT (2 Ea)
7 = Namco EA-080-11100 SPDT (1 Ea)
8 = Namco EA-080-11100 SPDT (2 Ea)
9 = Moore (2 SPDT Inside 760 Posit)
X = Other

Other - Position 22
0 = None
A = Moore Booster Relay (61H) (A39502)
X = Other

CE - Position 23 & 24
0 = None
CE = CE

K-MAX C_v

Valve Size in (mm)	CV (Flow to Open)				CV (Flow to Close)			
	FULL	0.6	0.4	0.2	FULL	0.6	0.4	0.2
1" (25)	14	8.4	5.6	2.8	15	9	6	3
1 1/2" (38)	32	20	13	6.5	34	21	14	7
2" (51)	51	30	20	10	55	33	22	11
3" (76)	150	90	60	30	155	93	62	31
4" (102)	247	147	98	49	266	159	106	53
6" (152)	520	312	208	104	480	288	192	96
8" (203)	870	522	348	174	800	480	320	160

Note: Consult factory for configurations not listed above. Add accessories and other options as separate line items.

1. Separable flanges available in 1" - 6" (25-152 mm), ANSI 150-300 only.
2. Optional in 316 & CS valves.
3. Use code 6 for shutoff classification. TFE seats 1" - 2" (25-51 mm) Full Cv only.
4. With Viton O-ring Bearing Seals
5. Includes Yoke kit.

Consult Factory for Quick Delivery options *Consult Factory



INTELLIGENT THERMAL UTILITIES SOLUTIONS FROM A GLOBAL
LEADER IN ENERGY MANAGEMENT AND ENJOYABLE EXPERIENCES

Armstrong International

The Americas | Asia | Europe, Middle East, Africa

[armstronginternational.com](https://www.armstronginternational.com)